



---

**BUDAPEST UNIVERSITY OF TECHNOLOGY AND ECONOMICS**

**FACULTY OF CIVIL ENGINEERING**

**DEPARTMENT OF STRUCTURAL MECHANICS**

1111 Budapest, XI., Műegyetem rkp. 3.

# **Numerical models for structures**

---

## **DEM analysis of Derand's Cathedral Design Rule**

Course homework

**2014/15/II.**

Dávid JOBBÁGY (FCMTCX)

Supervisor: Dr. Katalin BAGI



Course Homework for

**Dávid Jobbágy**

to partially fulfil the requirements of the subject

## Numerical Models for Structures

Title:

### **DEM analysis of Derand's Cathedral Design Rule**

Short description:

Gothic master builders applied purely geometrical rules when designing the dimensions of a structure. Derand gave a requirement on the pillar thickness supporting pointed or circular arches. The aim of the HW is to check the validity of this rule for an arch, with the help of discrete element simulations.

- Build a Gothic arch with an inner span of 4 m, based on an equilateral triangle. The length of the structure (perpendicularly to the plane of the arch) should be set to 1 m. The arch thickness is 40 cm. In order to take advantage of the symmetry of the problem, only the half of the structure is to be modelled.
- The arch consists of 8 discrete elements, and it is supported from below with a pillar of 4 m height consisting of 8 discrete elements. The pillar should rest on a fixed bottom block while the left face of the crown should be supported by a lateral fixed block with a frictionless contact.
- In the first case set the thickness of the pillar to 90 cm, slightly smaller than required by the Derand rule; in the second case set it to 100 cm, slightly above the thickness required by Derand.
- Use linearly elastic deformable blocks with the characteristics of a usual sandstone. The contacts should be cohesionless, with a friction coefficient equal to 0,75.
- Initially the whole system should be fixed when switching on the gravity. Release the blocks gradually proceeding downwards, as if de-centring a real structure. What happens?

Submission deadline:

02 April 2015

Prof. Katalin Bagi

lecturer

# Contents

Contents .....	1
I. Introduction .....	3
I.1. Problem description, goal of work .....	3
I. Solution strategy .....	4
II. Discrete element model.....	4
II.1. Geometry.....	4
II.2. Material model of blocks .....	4
II.3. Material model of contacts.....	4
II.4. Boundary conditions .....	5
II.5. Loading conditions.....	5
III. Results.....	5
III.1. Results of the arch with pillars of 1,0 m width.....	5
III.2. Results for the arch with pillars of 90 cm width.....	7
III.3. The critical width of the pillars.....	10
IV. Conclusions .....	11
V. References.....	12
VI. Appendix .....	13
VI.1. Code for 3DEC .....	13

# I. Introduction

## I.1. Problem description, goal of work

The goal of this work is to analyse Derand's rule of thumb regarding the width of pillars of cathedrals. These cathedrals and other buildings those times, were built without any calculation. The dimensions of these structures were based on empirical rules, which often were the result of earlier tries and failures. Of course the intuition of the masterbuilders had a great influence. These rules mostly were given in such way, that they gave a rough estimation regarding some dimensions.

Derand made some rules also related to arches. One of them is related to the maximum height of the supporting pillar, while another gives a restriction for the minimum width of them. This second is represented in *figure I.1.* Thus in order to get the minimum width of the pillar one should divide the inner part of the arch into three curves with equivalent length. Then a line has to be drawn on one of the trisecting point and the bottom point nearest to it. Then this line is extended by the distance of these points. The homework contains the analysis of this second rule with the help of discrete element method. The 3DEC software of Itasca is used.

In this project a single arch is under examination. The arch is based on an equilateral triangle with a span of 4.0 m. The arch thickness is 40 cm, while the supporting pillars have a height of 4.0 m (see *figure II.1.*). The longitudinal length is 1.0 m. According to Derand's law, this arch must be supported by a pillar with 94 cm width at least. Two pillar widths were taken into account. One of them is a little above Derand's suggestion – 1.0 m - , and the other is slightly below that - 90 cm -. The aim is to decide whether Derand's rule of thumb is an appropriate estimation for the width of pillars. Only self-weight was taken into account. The critical width was determined also.

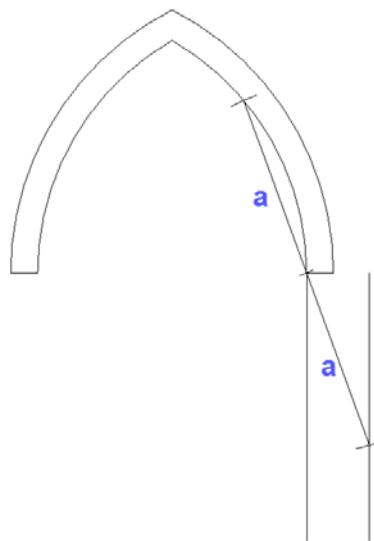

I.1. figure: Representation of Derand's rule.

## I. Solution strategy

For the analysis a 3D discrete element model was built up for both cases – for the wide and one for the slim -. In the model the arch consists of polyhedrons. The coordinates were determined in Excel. After applying the supports, loads, material and contact properties it was possible to run the calculation. After the calculation come conclusions - based on the results (displacements, contact forces etc.) - were made.

## II. Discrete element model

### II.1. Geometry

For the sake of simplicity and for time sparing only the half of the arch was modelled (*figure II.1.*). The arch contains 8 blocks and the pillar is built up by 8 pieces also.

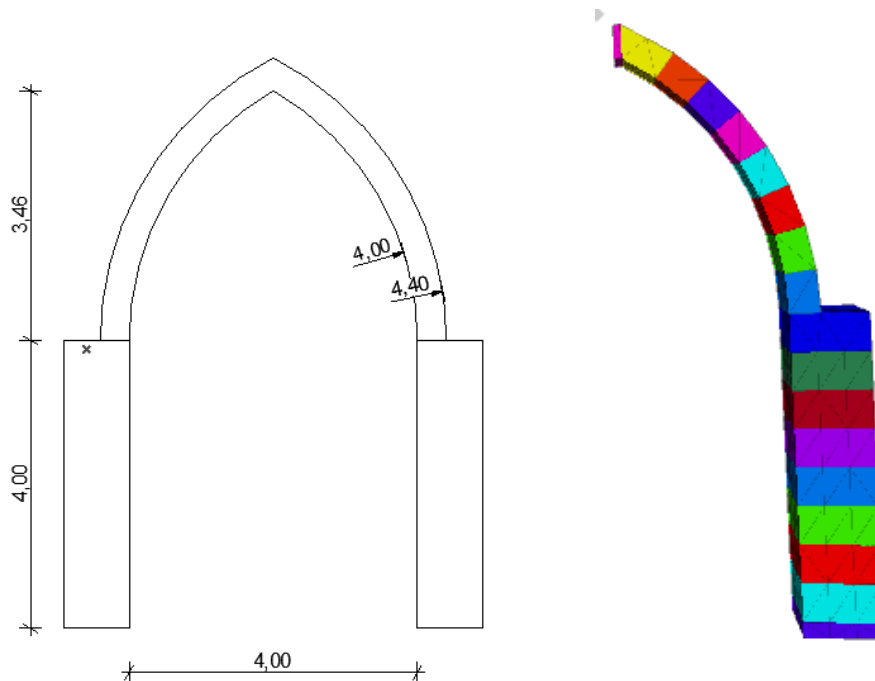

II.1. figure: The geometry of the structure and the discrete element model.

### II.2. Material model of blocks

The elements are deformable with linear elastic behaviour. The structure is made of sandstone, the material properties are set for usual values of that ( $E=19.3\text{GPa}$ , Poisson-ratio: 0.38 ,  $K=26.8\text{GPa}$   $G=7\text{GPa}$ ). The density was chosen to  $2400\text{ kg/m}^3$ .

### II.3. Material model of contacts

The contacts are cohesionless with a friction coefficient of 0.75. Joint shear and normal stiffness is  $10^{10}\text{ N/m}^2$ .

## II.4. Boundary conditions

The bottom of the pillars is simply supported. Supports were defined with the help of some blocks whose velocities are zero, thus they cannot move. One supportblock is at the bottom of the pillar, while another is on the top, next to the peak block of the arch. This upper supportblock was also fixed, but the friction coefficient between the peak block and this supportblock was chosen for low enough – 0.02 - to model a frictionless contact. This kind of support was applied to take advantage of the symmetry of the problem. As for the calculation at first all of the blocks were fixed and then the blocks of the structure were gradually released, proceeding downwards.

## II.5. Loading conditions

As it is written above only self-weight was applied.

## III. Results

The most important results of the calculation are the displacements and contact forces. The unbalanced force diagram is important also, for instance for deciding whether the calculation converge or not. The vertical displacement of the top of the arch and the horizontal displacement of the top of the pillar are plotted for all of the calculations. Displacement figures help to understand the structural response.

### III.1. Results of the arch with pillars of 1,0 m width

The unbalanced forces shows that the calculation converges (*figure IV.1.*).

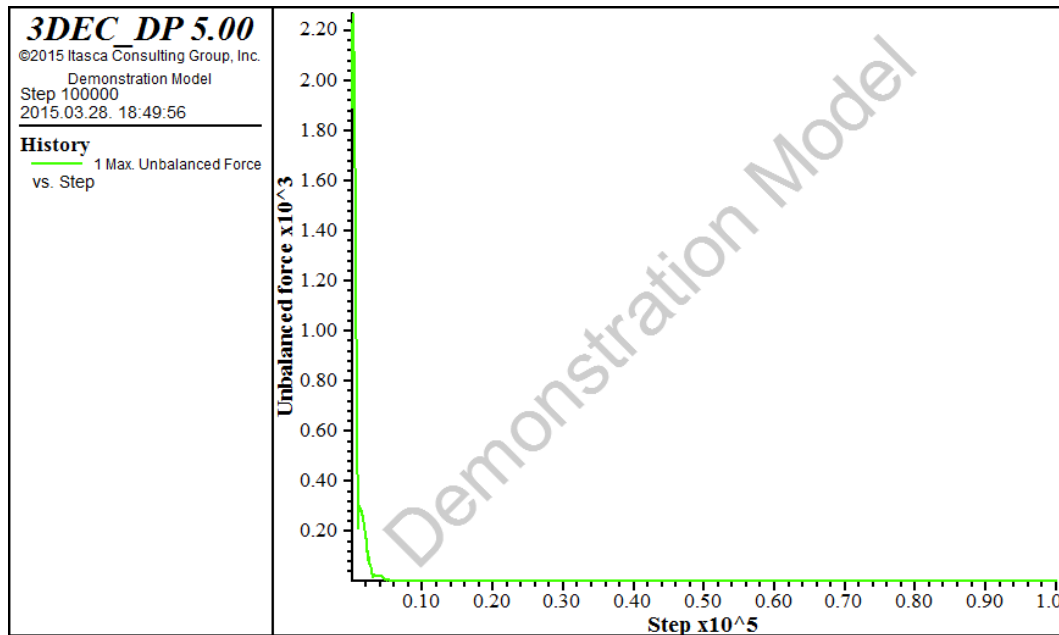

III.1. figure: The unbalanced forces of the arch with 1,0 m width pillar.

According to the displacements figures and the displacement-step diagrams, the results are reasonable (see *figureIV.2-IV.3.*). The situation of top point and point2 are represented below. As one can expect the top block does not move horizontally, and the bottom support is unmoving.

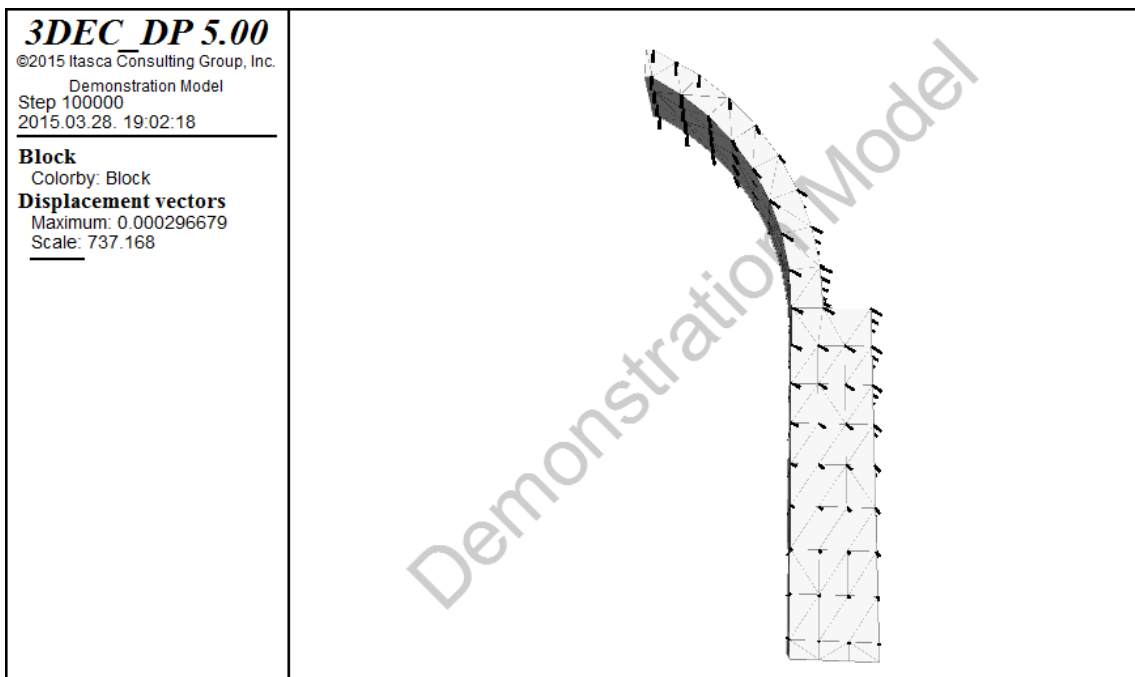
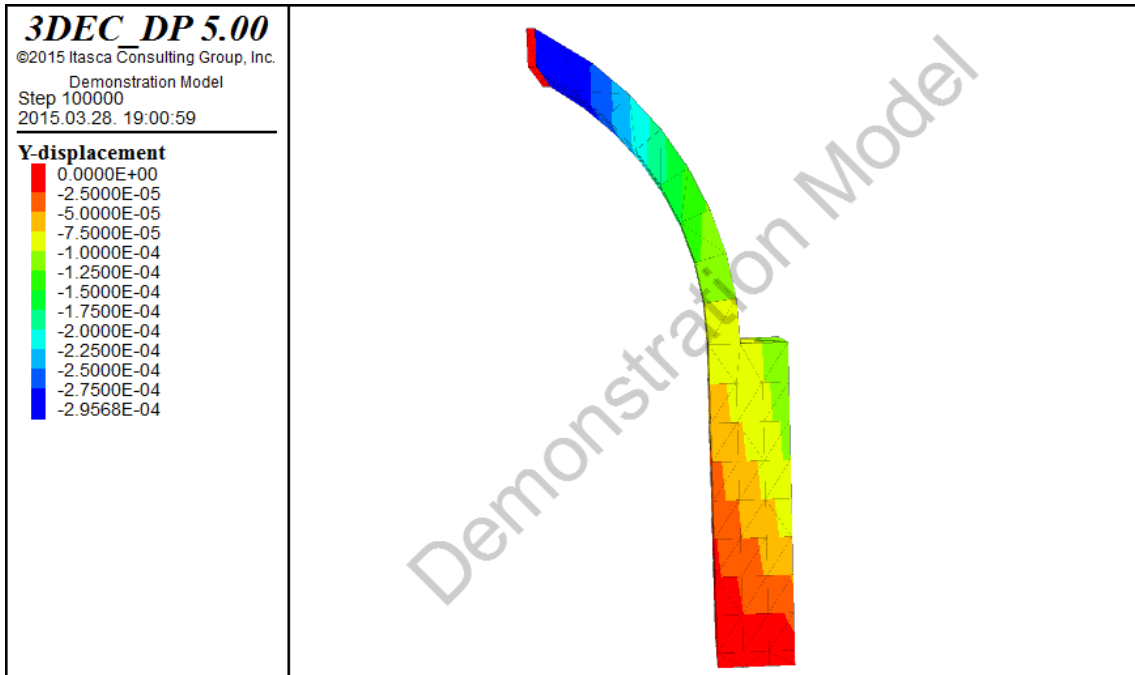

III.2. figure: The vertical displacement figure (above) and the figure of displacement vectors (down).

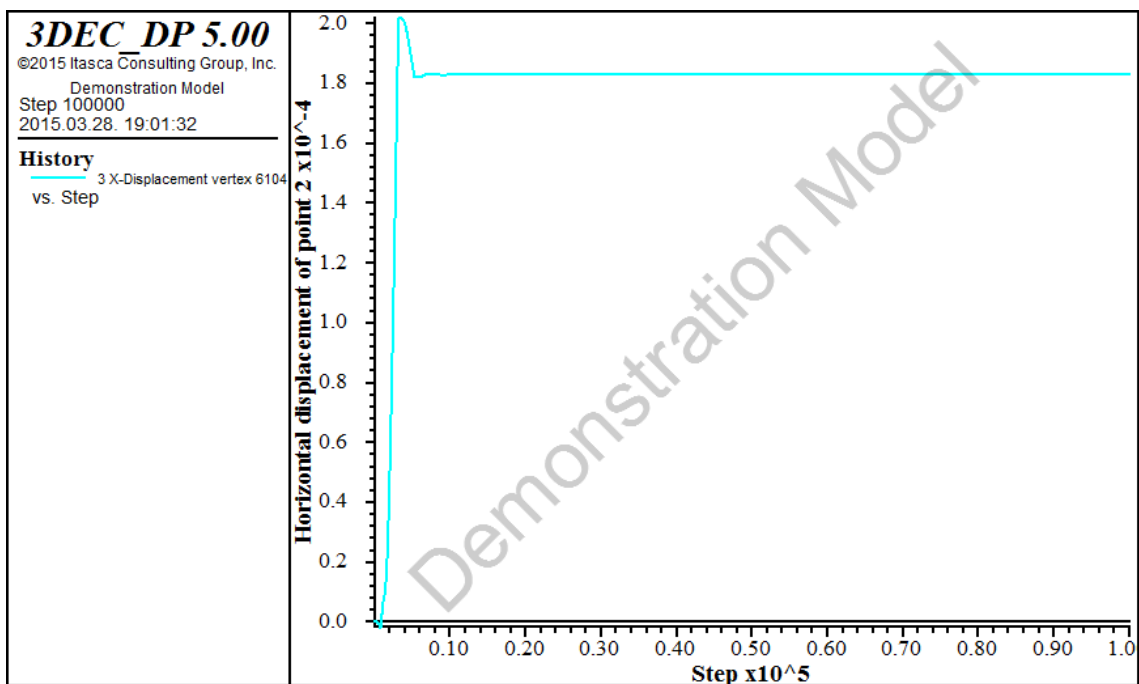
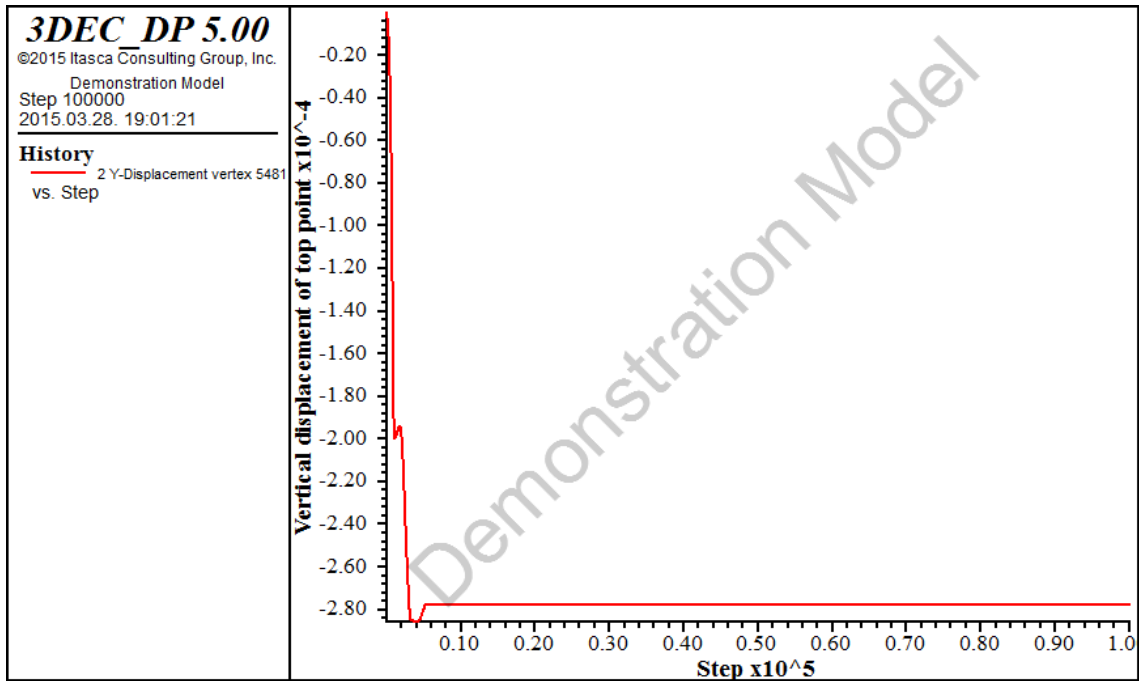

III.3. figure: Displacement diagrams of top point and point2.

On grounds of these results one can make a conclusion that the pillars with 1.0 m width are acceptable.

### III.2. Results for the arch with pillars of 90 cm width

See *figure IV.4.* for the unbalanced forces. One can see that this calculation also converges. See *figure IV.5.-6.* for displacement figure and diagrams.



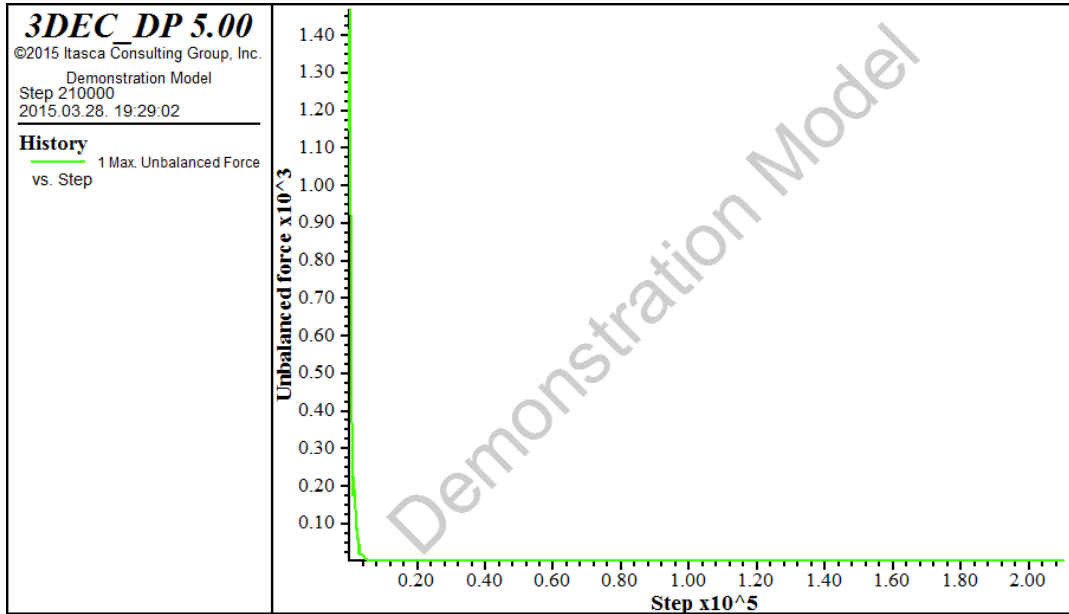

III.4. figure: Unbalanced forces.

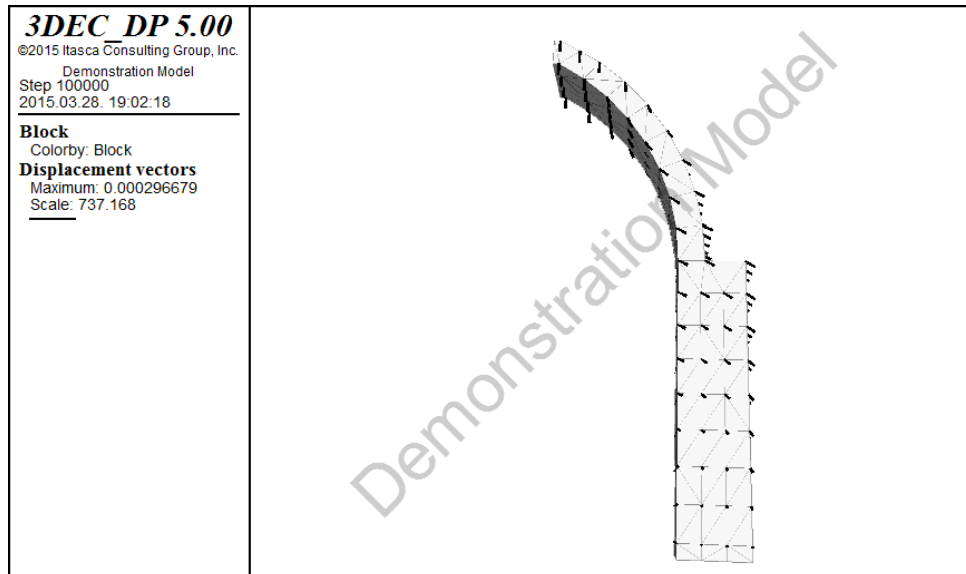
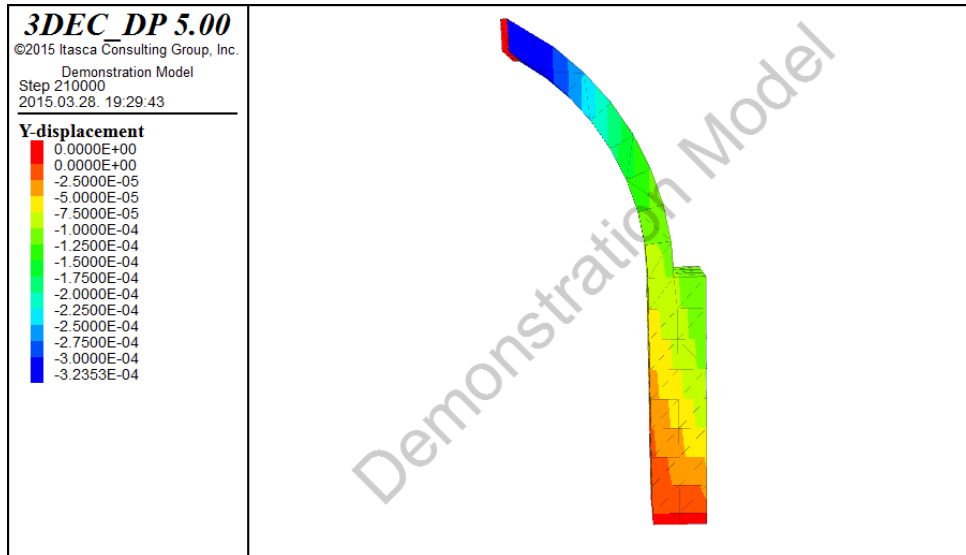

III.5. figure: Figure of vertical displacements and displacement vectors.

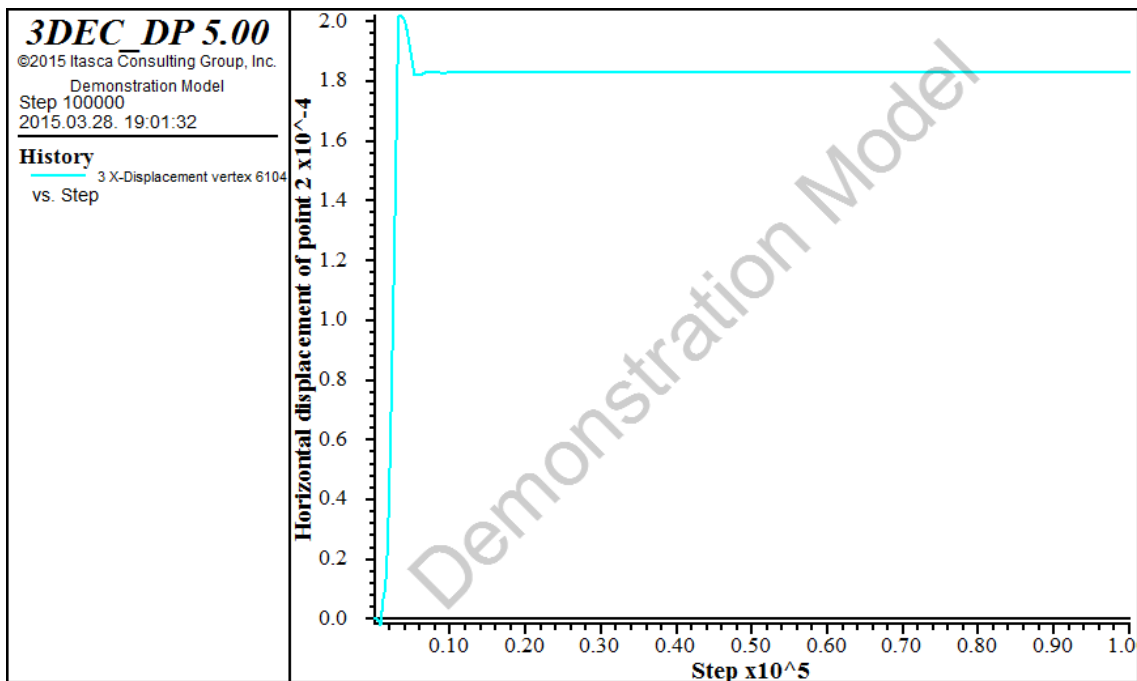
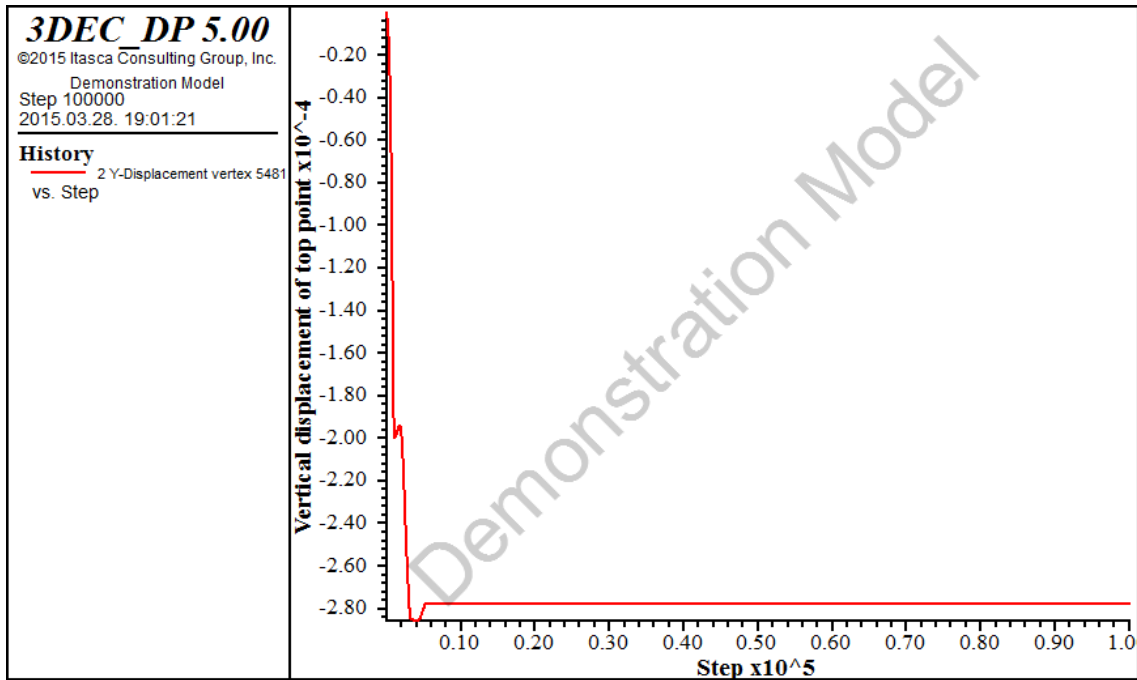

III.6. figure: Displacement diagrams of top point and point2.

According to these results it is obvious that the pillars with 90 cm width are also acceptable for this arch. This means that Derand's rule is conservative. In order to analyse whether it is a rough or a quite precise approximation the critical width of the pillars was determined.

### III.3. The critical width of the pillars

In order to do that a parametric analysis was carried out. The parameter was the width of the pillars. According to this the critical width for this structure is 53 cm – with 53 cm the structure is stable but at 52 cm the collapse occurs - . See *figure IV.7-8-9.* for diagrams of unbalanced forces and displacements. Neither the unbalanced forces nor the displacements of the characteristic points do converge to a value. See *figure IV.10.* for the mechanism with three hinges – top of arch, bottom of arch and bottom of the pillar - .

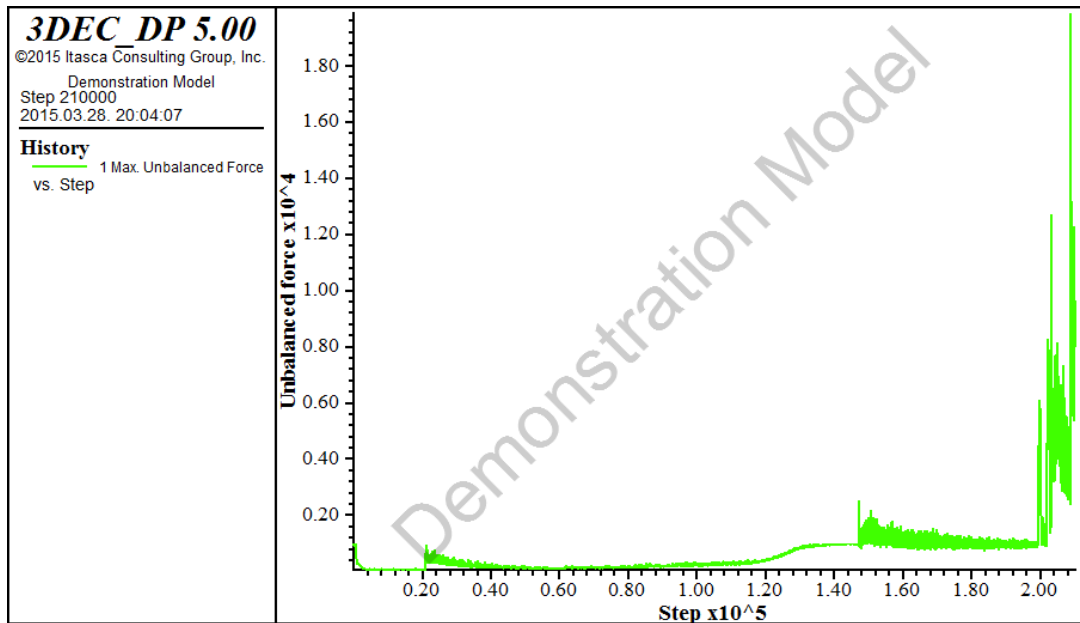

III.7. figure: Unbalanced forces.

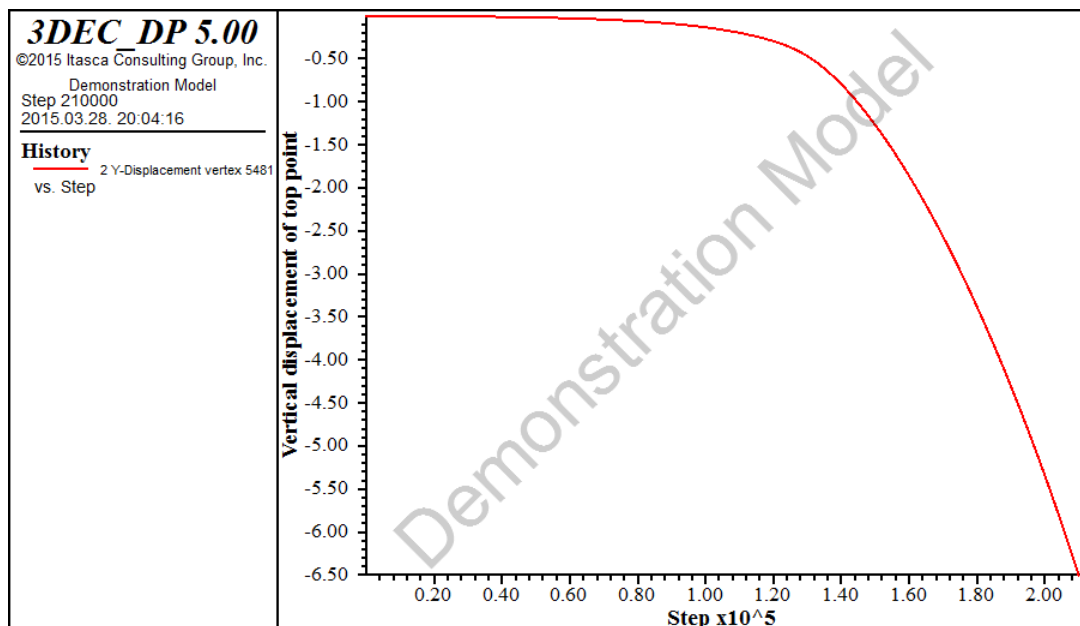

III.8. figure: Vertical displacement versus calculation step diagram of top point.

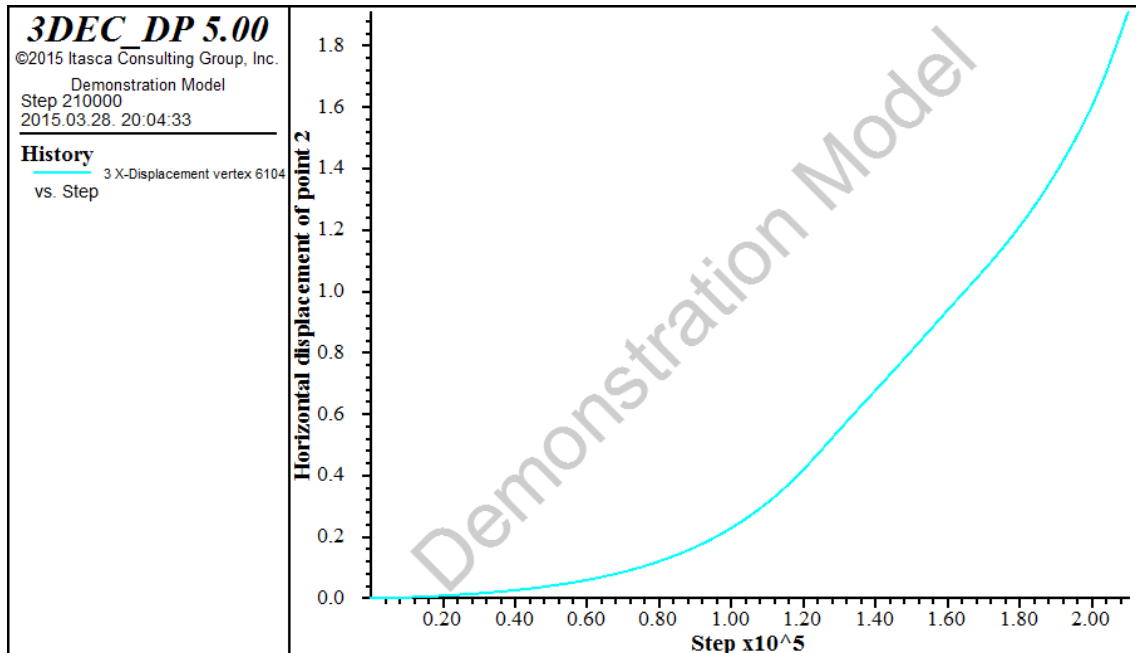

III.9. figure: Horizontal displacement versus calculation step diagram of point2.

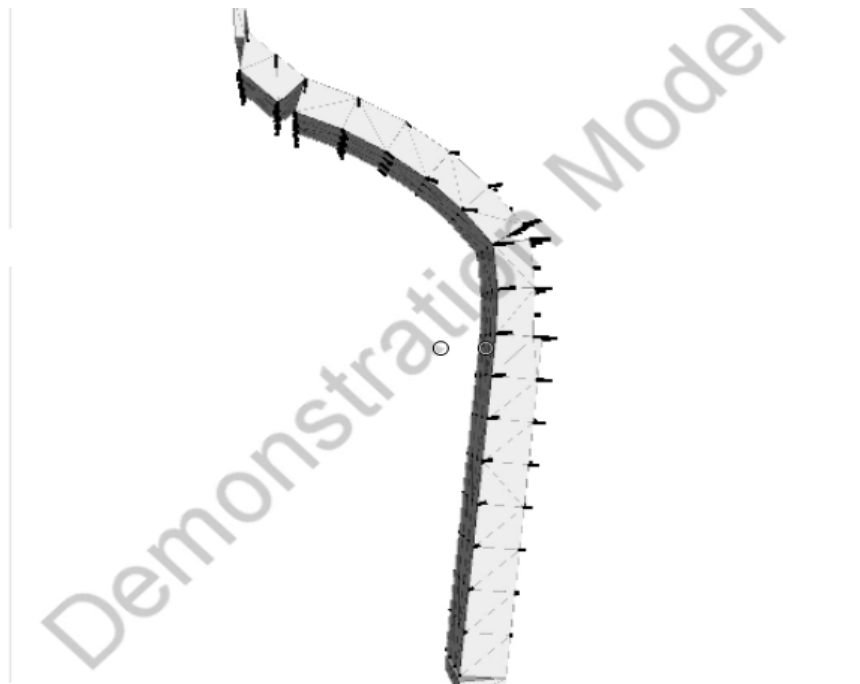

III.10. figure: Mechanism with three hinges. That single block on the top is the supportblock.

Thus the critical width is well below Derand's suggestion.

## IV. Conclusions

On the grounds of the results discussed above it is possible to evaluate Derand's suggestion for the width of pillars. According to the discrete element simulations the

critical width for the pillars is 53 cm which is much more below than his approximation – 94 cm - . Thus Derand’s rule is quite a rough one well on the safe side.

## V. References

- [1] Katalin Bagi, Lecture notes - Discrete Element Modelling; see [page](#)
- [2] Itasca: 3DEC - 3 Dimensional Distinct Element Code - Online Manual (User’s Guide: Introduction, Getting Started, Problem Solving with 3DEC)
- [3] Zsuzsa Borbála Papp, DEM comparison of the horizontal reaction of Romanesque and Gothic arches, Homework for Numerical Models for Structures, 2014 see [page](#)
- [4] N. Turi, 3DEC version 4.1 Tutorial, Guide for Numerical Models for Structures, 2014 see [page](#)

## VI. Appendix

### VI.1. Code for 3DEC

new

;Defining the geometry with polyhedrons  
;Definig a variable for the geometry input (aa)

def aa  
aa=4.9  
end

;arch

polyhedron prism a 4,0,0.000 4.4,0.000,0.000 4.362,0.574,0.000 3.966,0.522,0.000 b  
4,0,1 4.4,0.000,1 4.362,0.574,1 3.966,0.522,1  
polyhedron prism a 3.966,0.522,0.000 4.362,0.574,0.000 4.25,1.139,0.000  
3.864,1.035,0.000 b 3.966,0.522,1 4.362,0.574,1 4.25,1.139,1 3.864,1.035,1  
polyhedron prism a 3.864,1.035,0.000 4.25,1.139,0.000 4.065,1.684,0.000  
3.696,1.531,0.000 b 3.864,1.035,1 4.25,1.139,1 4.065,1.684,1 3.696,1.531,1  
polyhedron prism a 3.696,1.531,0.000 4.065,1.684,0.000 3.811,2.2,0.000  
3.464,2.00,0.000 b 3.696,1.531,1 4.065,1.684,1 3.811,2.2,1 3.464,2.00,1  
polyhedron prism a 3.464,2.00,0.000 3.811,2.2,0.000 3.491,2.679,0.000  
3.173,2.435,0.000 b 3.464,2.00,1 3.811,2.2,1 3.491,2.679,1 3.173,2.435,1  
polyhedron prism a 3.173,2.435,0.000 3.491,2.679,0.000 3.111,3.111,0.000  
2.828,2.828,0.000 b 3.173,2.435,1 3.491,2.679,1 3.111,3.111,1 2.828,2.828,1  
polyhedron prism a 2.828,2.828,0.000 3.111,3.111,0.000 2.679,3.491,0.000  
2.435,3.173,0.000 b 2.828,2.828,1 3.111,3.111,1 2.679,3.491,1 2.435,3.173,1  
polyhedron prism a 2.435,3.173,0.000 2.679,3.491,0.000 2,3.919,0.000 2,3.464,0.000 b  
2.435,3.173,1 2.679,3.491,1 2,3.919,1 2,3.464,1

;pillar

polyhedron prism a 4,0,0.000 @aa,0.000,0.000 @aa,-0.5,0.000 4,-0.5,0.000 b 4,0,1  
@aa,0.000,1 @aa,-0.5,1 4,-0.5,1  
polyhedron prism a 4,-0.5,0.000 @aa,-0.5,0.000 @aa,-1,0.000 4,-1,0.000 b 4,-0.5,1  
@aa,-0.5,1 @aa,-1,1 4,-1,1  
polyhedron prism a 4,-1,0.000 @aa,-1,0.000 @aa,-1.5,0.000 4,-1.5,0.000 b 4,-1,1  
@aa,-1,1 @aa,-1.5,1 4,-1.5,1  
polyhedron prism a 4,-1.5,0.000 @aa,-1.5,0.000 @aa,-2,0.000 4,-2,0.000 b 4,-1.5,-  
1.5,1 @aa,-1.5,1 @aa,-2,1 4,-2,1  
polyhedron prism a 4,-2,0.000 @aa,-2,0.000 @aa,-2.5,0.000 4,-2.5,0.000 b 4,-2,1  
@aa,-2,1 @aa,-2.5,1 4,-2.5,1

```
polyhedron prism a 4.0,-2.5,0.000 @aa,-2.5,0.000 @aa,-3,0.000 4.0,-3,0.000 b 4.0,-2.5,1 @aa,-2.5,1 @aa,-3,1 4.0,-3,1
polyhedron prism a 4.0,-3,0.000 @aa,-3,0.000 @aa,-3.5,0.000 4.0,-3.5,0.000 b 4.0,-3,1 @aa,-3,1 @aa,-3.5,1 4.0,-3.5,1
polyhedron prism a 4.0,-3.5,0.000 @aa,-3.5,0.000 @aa,-4,0.000 4.0,-4,0.000 b 4.0,-3.5,1 @aa,-3.5,1 @aa,-4,1 4.0,-4,1
```

```
;blocks for supports
```

```
polyhedron prism a 2,3.464,0.000 2,3.919,0.000 1.9,3.919,0.000 1.9,3.464,0.000 b 2,3.464,1 2,3.919,1 1.9,3.919,1 1.9,3.464,1
polyhedron prism a 4.0,-4,0.000 @aa,-4,0.000 @aa,-4.2,0.000 4.0,-4.2,0.000 b 4.0,-4,1 @aa,-4,1 @aa,-4.2,1 4.0,-4.2,1
```

```
;ranges
```

```
range name arch x=(2,5) y=(-4,4) z(0,1)
range name supp1 x=(1.8,2) y=(0,4) z(0,1)
range name supp2 x=(4,5) y=(-5,-4) z(0,1)
```

```
;Applying supports
```

```
fix range supp1
fix range supp2
```

```
;Mesh generation
```

```
gen edge 0.4
```

```
;Material properties-Sandstone(density, bulk moduli, shear moduli respectively)
```

```
prop mat=1 dens=2400.0 k=2.68e10 g=7.0e9
```

```
;Contact properties-friction coeff. between the top block and the top support is changed to ~0.2
```

```
prop jmat=1 jkn 1.0e10 jks 1.0e10 jfri 36.87
prop jmat=2 jkn 1.0e10 jks 1.0e10 jfri 1.0
change jmat=2 range x=(1.95,2.05) y=(3,4) z=(0,1)
```

```
;Setting the gravity
```

```
gravity 0,-9.81,0
```

```
;Storing the unbalanced forces
```

hist unbal id=1

;Listing ydisp of the top of the arch and the xdisp of the top of the coloumn

hist ydisp (2.435,3.173,0.0) id=2

hist xdisp (4,0.0,0.0) id=3

;Releasing the first block

free range x 2.0,3.111

;Starting the calculation and releasing the other blocks

cycle 10000

hist sforce (2,3.919,0.0) id=4

hist sforce (4,0.0,0.0) id=5

hist nforce (2,3.919,0.0) id=6

hist nforce (4,0.0,0.0) id=7

pause

cycle 50000

free range x 3.111,3.811

cycle 50000

free range x 3.811,4.4 y 0,4

cycle 50000

free range y -4,0

cycle 50000

; Plotting figures

plot create plot 'Unbalanced f'

plot hist 1 yaxis label 'Unbalanced force'

plot create plot 'Vertical d'

plot hist 2 yaxis label 'Vertical displacement of top point'

plot create plot 'Horizontal d'

plot hist 3 yaxis label 'Horizontal displacement of point 2'

plot create plot 'ydisp'



plot contour ydisp above au

plot create plot 'xdisp'  
plot contour xdisp above au

plot create plot 'zdisp'  
plot contour zdisp above au  
plot block color white disp

list contact state  
list contact stress